

GOLDEN WHEEL

No. 007029

2-NEEDLE, NEEDLE FEED, SPLIT NEEDLE BAR LOCKSTITCH MACHINE

Please read this Instruction Manual carefully before using the unit in order to get the most out of it and to enjoy using it for a long time. Please keep this Instruction Manual at hand taking care not to lose it.

CS-8165	FOR MEDIUM MATERIALS
CS-8165-BT	WITH AUTOMATIC THREAD TRIMMER FOR MEDIUM MATERIALS
CS-8175	FOR HEAVY MATERIALS
CS-8175H-BT	WITH AUTOMATIC THREAD TRIMMER FOR MEDIUM MATERIALS
CS-8175-BT	WITH AUTOMATIC THREAD TRIMMER AND LARGE HOOK FOR HEAVY MATERIALS

INSTRUCTION MANUAL

BEFORE OPERATION

- 1 Do not operate the machine even for trial before lubrication it
- 2 Confirm that the voltage and phase (single or 3-phase) are correct by checking them against the ratings shown on the motor nameplate
- 3 When running your machine for the first time after the set-up, check the rotational direction of the handwheel. ★ Turn on the power switch. Run the machine at a low speed while checking the rotational direction of the handwheel. (The handwheel should turn counterclockwise as observed from the handwheel side.)
- 4 For the first month, run the machine at speed of 1800 r.p.m. or less.

CAUTIONS IN OPERATION

- 1 Keep your hands away from the needle when you turn on the power switch or while the machine is operating
- 2 During operation, be careful not to allow your or any other person's head or fingers to come close to the handwheel, V-belt, bobbin winder or motor. Also, do not place anything close to them.
- 3 Do not turn the machine with the finger guard, belt cover or any other protectors removed.
- 4 Be sure to turn off the power switch and confirm that the motor is completely stopped before removing the V-belt.

SPECIFICATIONS

Spec	Model	CS-8165/-BT	CS-8175H-BT	CS-8175/-BT
Application		Medium material	Medium material	Medium ~ heavy material
Sewing speed (Max)		※, 3000 (spm)	※, 3000 (spm)	※, 3000 (spm)
Stitch length		0~5 (mm)	0~5 (mm)	0~7 (mm)
Needle bar stroke		33.46 (mm)	33.46 (mm)	33.46 (mm)
Presser foot stroke	Knee lifter	9 (mm)	9 (mm)	13 (mm)
	Hand lifter	7 (mm)	7 (mm)	7 (mm)
Needle		DPx5 #14	DPx5 #16	DPx5 #18
Lubricating oil		Machine oil (white spindle oil)		

※depending on the gauge size.

※depending on the stitch length (5mm:2800spm, 7mm:2500spm) and the gauge size.

1. MOUNTING POSITION OF THE KNEE LIFTER

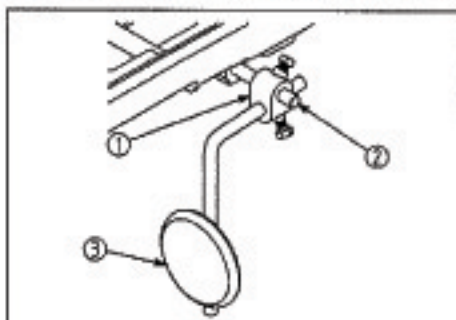

- 1) Insert knee lifter crank ① in the knee lifter shaft ②
- 2) Attach knee lifter plate rod asm ③ to the knee lifter crank ①

2. ADJUSTMENT OF NEEDLE BAR STOP POSITION

⚠ CAUTION TURN THE SWITCH OFF THE POWER SUPPLY TO PREVENT FROM UNEXPECTED INJURY. BE SURE TO CONFIRM THE STOP OF ROTATION OF THE MOTOR BEFORE OPERATIONS.

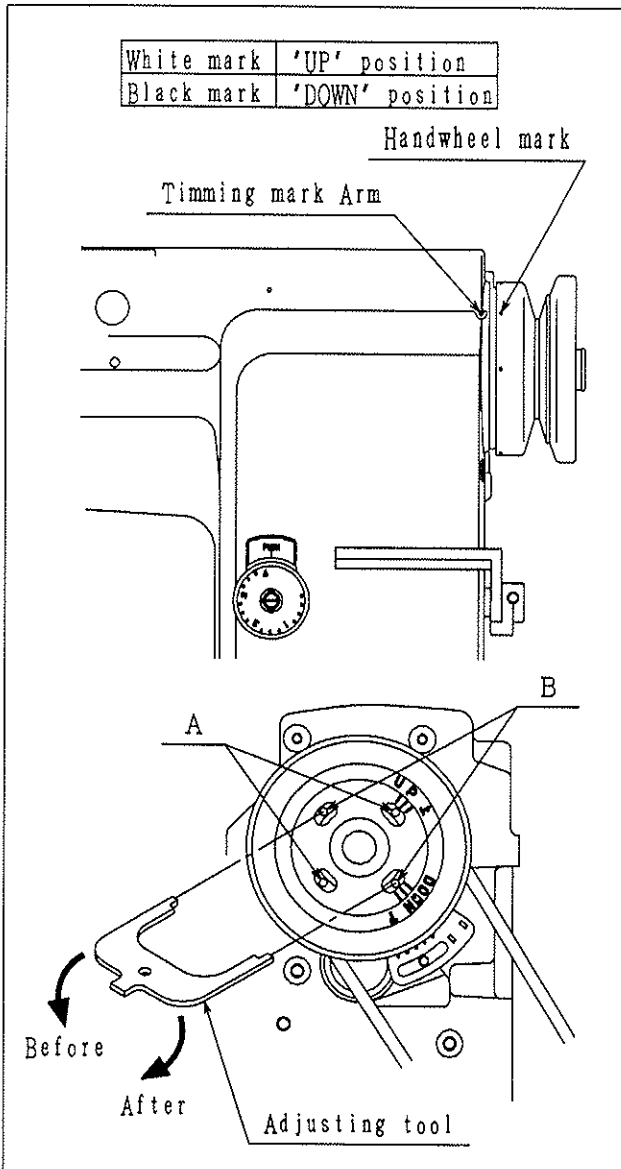

1) Adjust of 'UP' position

When the pedal is kicked down by heel, the machine stops at 'UP' position. If the marks deviate larger than 3 mm, adjust as follows.

- ① Disconnect the plug (12 pins) of cable from the machine head.
- ② Run the machine and stop at 'UP' position.
- ③ While holding the handwheel, insert the 'adjusting tool' in the hole 'A', then remove the tool.

2) Adjust of 'DOWN' position

When the pedal is 'Neutral' the machine stops at 'DOWN' position. If the marks deviate larger than 5 mm, adjust as follows.

- ① Disconnect the plug (12 pins) of cable from the machine head.
- ② Run the machine and stop at 'DOWN' position.
- ③ While holding the handwheel, insert the 'adjusting tool' in the hole 'B', then remove the tool.

- 3) Confirm the stop operation, then set the plug (12 pins) coming from the machine head into the receptacle.

3. LUBRICATION (1)

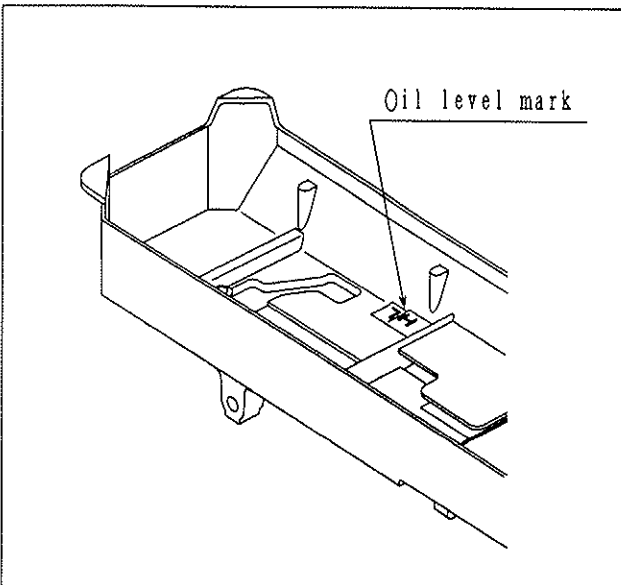

Fill the oil reservoir with oil up to 'H' mark. Oil level should be periodically checked. If oil level is found below 'L' level, replenish oil to 'H' level. Using oil is white spindle oil.

LUBRICATION (2)

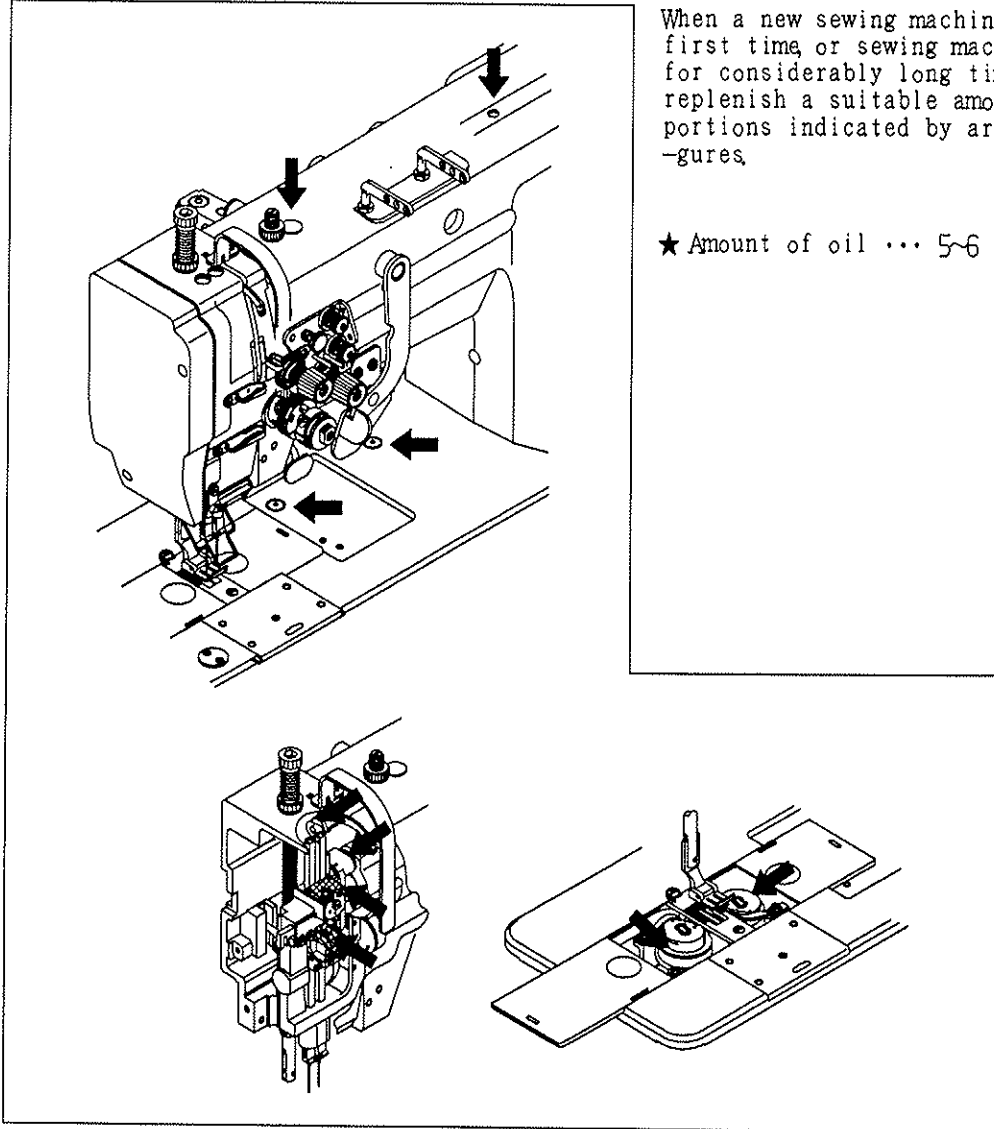

4. OILING CONDITION AND ADJUSTMENT ON OILING TO THREAD TAKE-UP LEVER

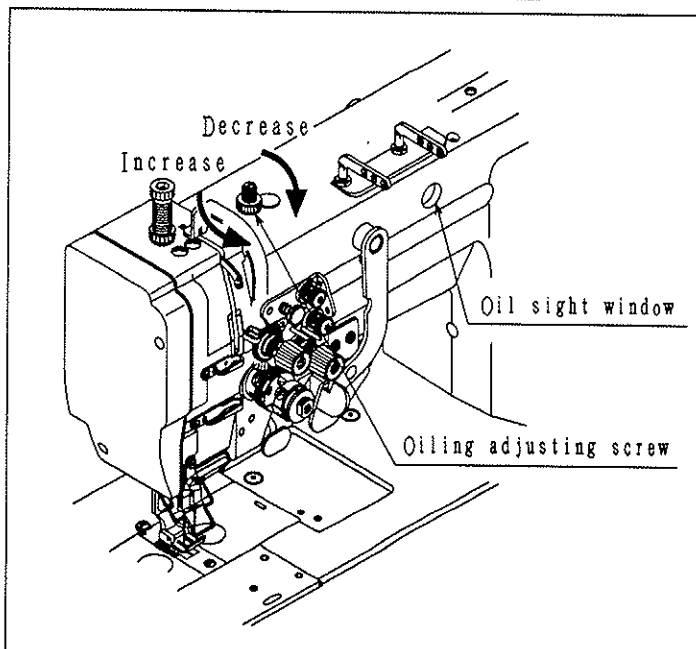

- 1) See dripping of oil during operation through the oil sight window to check oiling condition in the machine arm
- 2) Please use the oiling adjusting screw with respect to oiling to thread take-up lever mechanism

5. REFUELING ADJUSTMENT OF THE HOOK.



CAUTION

TURN THE SWITCH OFF THE POWER SUPPLY TO PREVENT FROM UNEXPECTED INJURY. BE SURE TO CONFIRM THE STOP OF ROTATION OF THE MOTOR BEFORE OPERATIONS.

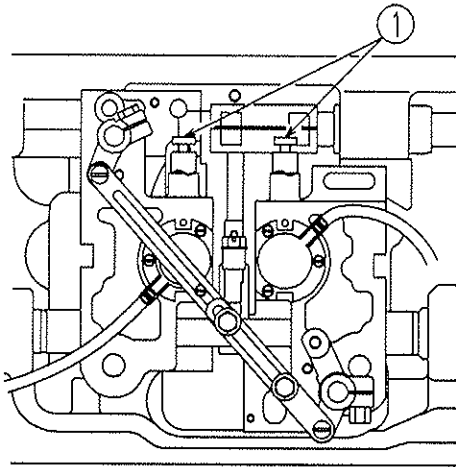

Decrease Increase

If it is necessary to change the amount of oil supplied to the hook, adjust it using knob ①

- Turn the knob clockwise (in direction '+') to increase the oil supplied, or turn it counterclockwise (in direction '-') to decrease it.

Attention:

After adjusting the knob and no-load running more than 30 seconds, confirm oil which scatters from the hook

6. INSTALLATION OF NEEDLES



CAUTION

TURN THE SWITCH OFF THE POWER SUPPLY TO PREVENT FROM UNEXPECTED INJURY. BE SURE TO CONFIRM THE STOP OF ROTATION OF THE MOTOR BEFORE OPERATIONS.

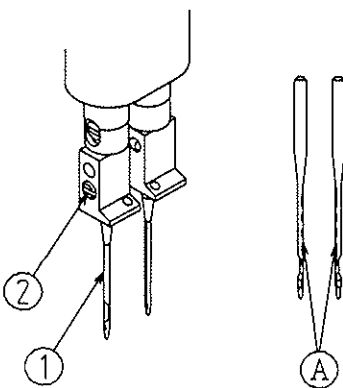

- 1) Turn the handwheel to move the needle bar up to its highest position
- 2) Loosen needle setscrew ②, and hold needle ① so that long groove A oppositely each other.
- 3) Insert the needle into the needle bar until it will go no further.
- 4) Securely tighten the needle set screw ②

7. WINDING OF BOBBIN THREAD



CAUTION TURN THE SWITCH OFF THE POWER SUPPLY TO PREVENT FROM UNEXPECTED INJURY. BE SURE TO CONFIRM THE STOP OF ROTATION OF THE MOTOR BEFORE OPERATIONS.

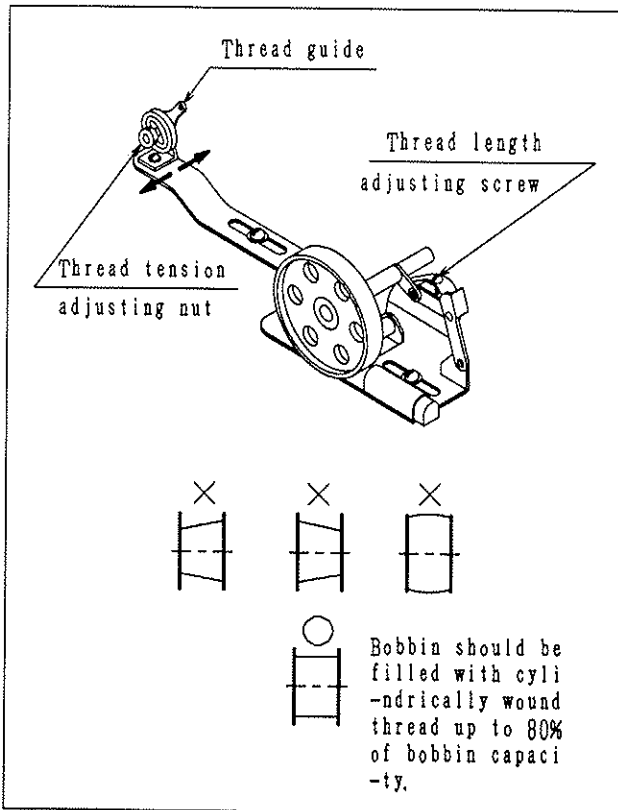

- Tension of wound thread
Slack winding is recommended for polyester thread and nylon thread
- Conically wound thread
Move the thread guide toward smaller diameter of wound thread layer.
- Length of wound thread
Loosen the thread length adjusting screw to increase length of thread and tighten the screw to decrease length of thread

8. THREADING THE MACHINE HEAD



CAUTION TURN THE SWITCH OFF THE POWER SUPPLY TO PREVENT FROM UNEXPECTED INJURY. BE SURE TO CONFIRM THE STOP OF ROTATION OF THE MOTOR BEFORE OPERATIONS.

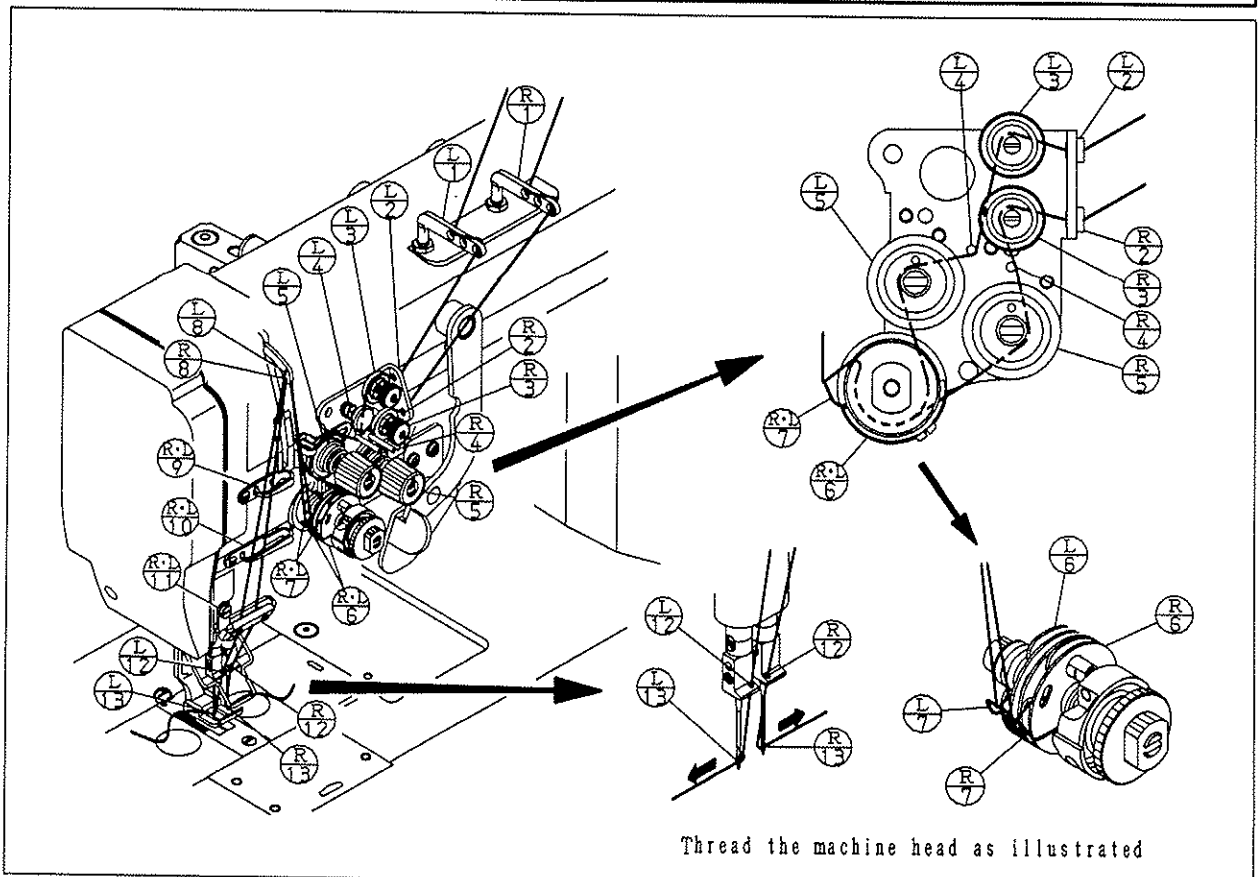

9. ADJUSTMENT OF STITCH LENGTH AND STITCH REVERSING (TOUCH-BACK)

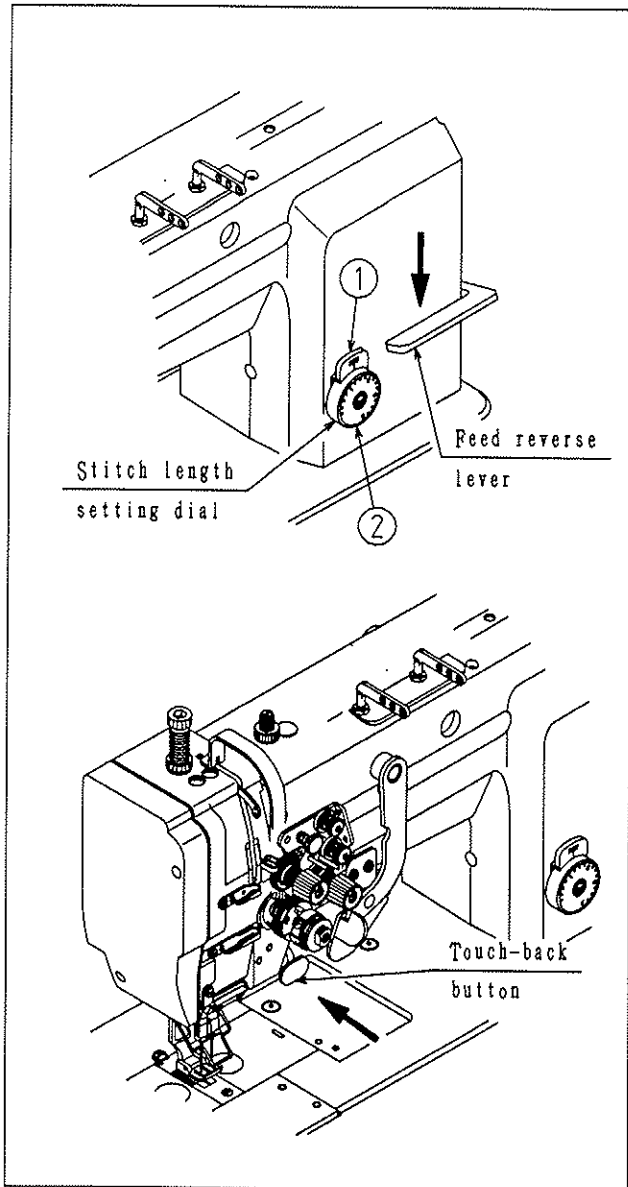

○ Stitch length setting dial

Push the stopper plate ①, and turn the dial ②

○ Feed reverse lever

How to operate

- ① Push feed reverse lever down
- ② The machine performs reverse feed stitching as long as the lever is held depressed
- ③ The moment you release to lever, the machine resumes the normal stitching mode

○ Touch-back button

How to operate

- ① The moment you press touch-back button, the sewing machine performs reverse feed stitching
- ② The machine continues reverse feed stitching as long as the touch-back button is held pressed
- ③ When you release the switch, the machine resumes normal stitching

10. ADJUSTING OF NEEDLE THREAD GUIDE

⚠ CAUTION

TURN THE SWITCH OFF THE POWER SUPPLY TO PREVENT FROM UNEXPECTED INJURY. BE SURE TO CONFIRM THE STOP OF ROTATION OF THE MOTOR BEFORE OPERATIONS.

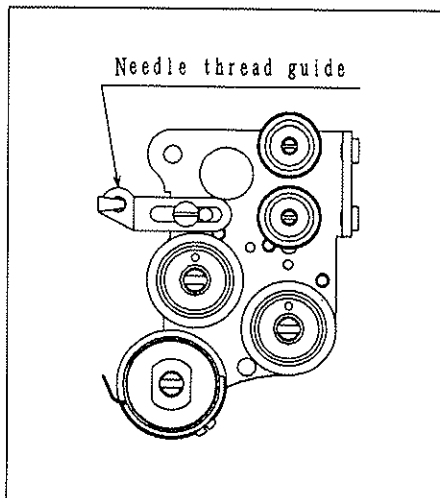

Please adjust needle thread guide of needle thread tensioner according to sewing condition

Thread guide position	Left	Middle	Right
Materials	The thicker than standard	Standard	The thinner than standard
Needle thread supply	More	Standard	Less

11. THREADING OF BOBBIN THREADS



CAUTION TURN THE SWITCH OFF THE POWER SUPPLY TO PREVENT FROM UNEXPECTED INJURY. BE SURE TO CONFIRM THE STOP OF ROTATION OF THE MOTOR BEFORE OPERATIONS.

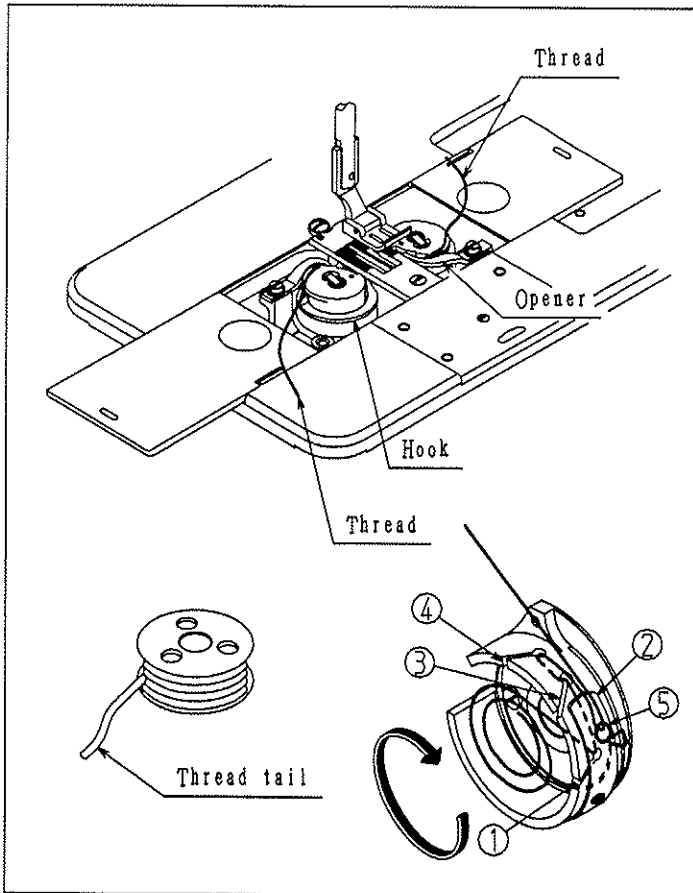

○ Setting bobbin

- 1) Pull out 5cm thread tail from the bobbin
- 2) Hold the bobbin so that the bobbin thread is wound in right direction and put it into the hook

○ Threading of bobbin threads

- 1) Pass bobbin thread into the slit ①, pass under the tension spring ②.
- 2) Pass thread through another thread slit ③ then pass it through slit ④ on the bobbin case from the inside.
- 3) Put the thread on bobbin thread slack preventer spring ⑤.

NOTE: Fit the bobbin in the bobbin case so that the bobbin turns in the direction of the arrow when the bobbin thread is pulled.

12. THREAD TENSION



CAUTION TURN THE SWITCH OFF THE POWER SUPPLY TO PREVENT FROM UNEXPECTED INJURY. BE SURE TO CONFIRM THE STOP OF ROTATION OF THE MOTOR BEFORE OPERATIONS.

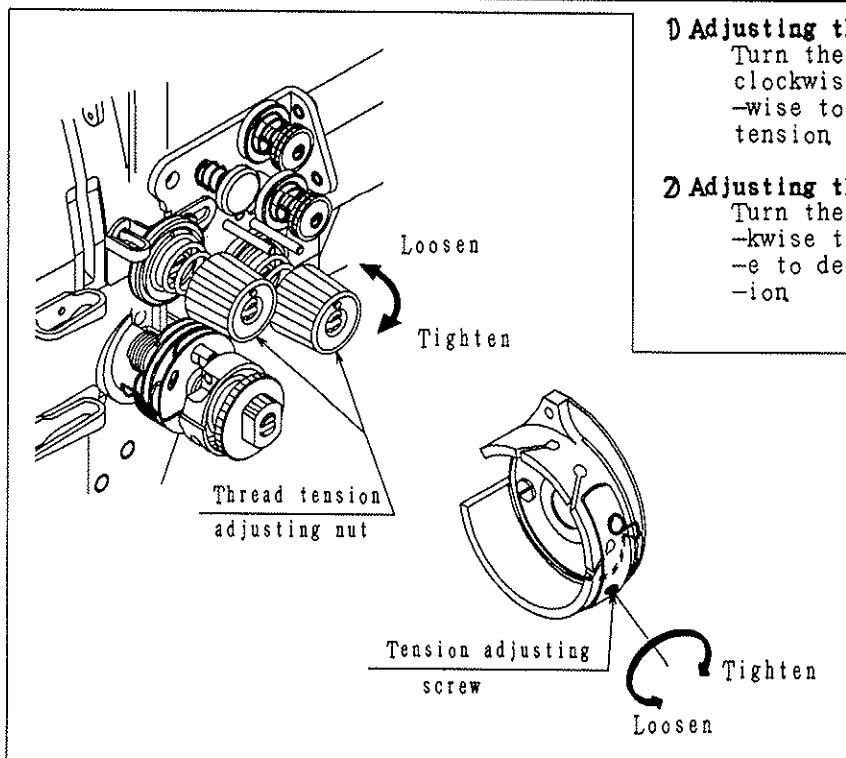

1) Adjusting the needle thread tension

Turn the thread tension adjusting nut clockwise to increase or counterclockwise to decrease the needle thread tension.

2) Adjusting the bobbin thread tension

Turn the tension adjusting screw clockwise to increase or counterclockwise to decrease the bobbin thread tension.

13. ADJUSTMENT OF PRESSER FOOT PRESSURE

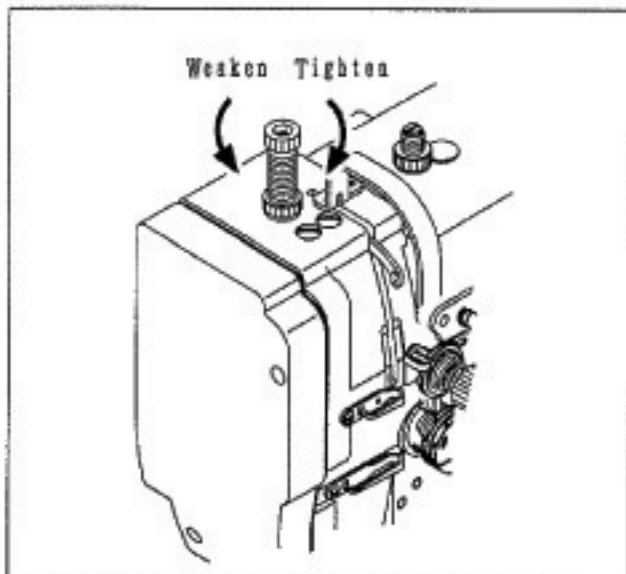

Pressure to fabric can be adjusted by turning the pressure adjusting screw

14. NEEDLE TO HOOK RELATIONSHIP



CAUTION

TURN THE SWITCH OFF THE POWER SUPPLY TO PREVENT FROM UNEXPECTED INJURY. BE SURE TO CONFIRM THE STOP OF ROTATION OF THE MOTOR BEFORE OPERATIONS.

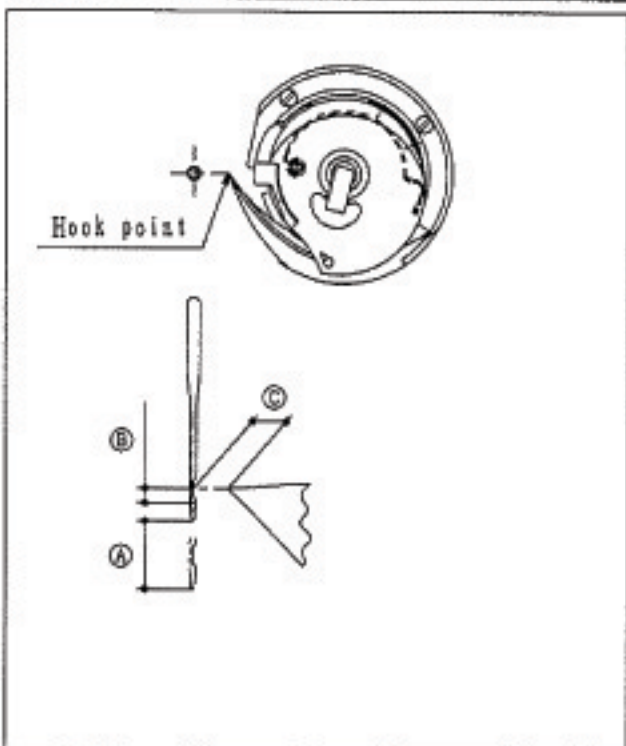

① Set stitch length on the stitch length setting dial shown table

② When needle is lifted ④ shown table, from the lowest position, the following positional relationship should be maintained

- The upper edge of needle eye should be 1.0~1.6mm below the hook point
- The hook point should be located at the center of needle axis
- Gap between the hook point and the side face of needle should be 0.05mm

③ Needle rotating hook position can be adjusted as follows

(For easy adjustment, it is recommended that the presser foot, throat plate and feed dog assemblies are removed)

Spec	Model	CS-B165/-BT	CS-B175H-BT	CS-B175/-BT
Set the stitch length		2	3	4.5
Needle lift ④		2.2 (mm)	2.2 (mm)	2.4 (mm)
Gap ②		1.0~1.6 (mm)		
Clearance ③		0.05 (mm)		

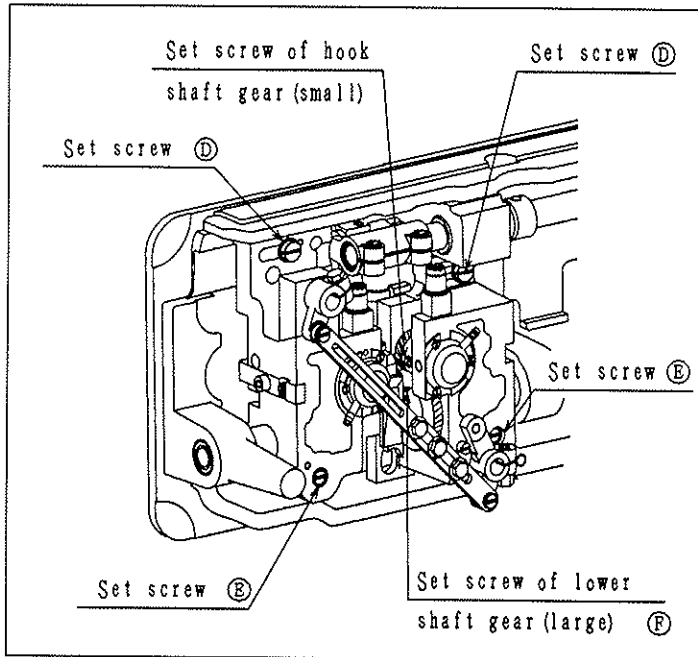

○ Position adjustment of hook point
Adjust the hook point so that it comes to the center of needle axis.

- ① Lean the machine head backward and loosen three set screws of hook shaft gear, (small)
- ② Turn the handwheel and stop when the needle is lifted ① mm shown table from the lowest position
- ③ Rotate the hook by hand to position the hook point to the center of needle axis.
- ④ Move the hook bracket leftward or rightward and position it so that gap between the hook point and side face of needle is 0.05 mm. For this adjustment, each screw ①, ② and three of ③ should be loosened.

Note: In the adjustment, do not excessively loosen set screws ③ and always maintain meshing of hook shaft gear and lower shaft gear.

- ⑤ Tighten the set screws in the following order.
- ① While pressing the lower shaft gear (large) against the side face of hook bracket, tighten the set screws ③ first.
 - ② After checking gap between the needle and the hook, tighten the set screws ①.
 - ③ Then tighten the set screws ②.

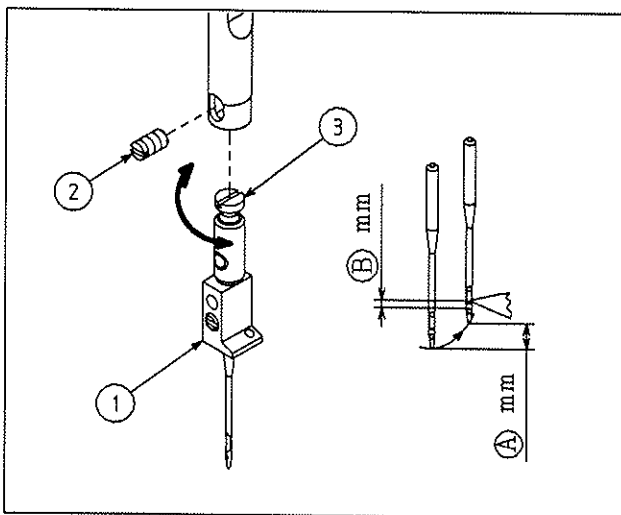

○ Position adjustment of needle point
Adjust needle position so that gap between the upper edge of needle eye and the hook point is ① mm when the needle is lifted by ① mm from its lowest position.

- ① Remove the needle clamp screw ② and then pull the clamp ① downward to remove it.
- ② Turn the screw ③ to adjust so that the distance from the upper edge of the needle hole to the hook is ① mm.
- ③ After adjustment, insert the needle clamp ① into the hole of the needle bar as far as it will go.

15. ADJUSTMENT OF FEED DOG HEIGHT

⚠ CAUTION

TURN THE SWITCH OFF THE POWER SUPPLY TO PREVENT FROM UNEXPECTED INJURY. BE SURE TO CONFIRM THE STOP OF ROTATION OF THE MOTOR BEFORE OPERATIONS.

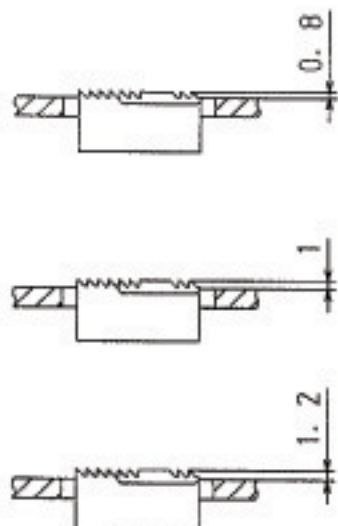

Height of feed dog and pressure of presser foot should be adjusted for individual fabric with the following cautions.

- ◆ Material will be damaged if the feed dog extends too high, or pressure of presser foot is too large.
- ◆ Even stitch length cannot be assured if the feed dog is too low or pressure of presser foot is too small.
- ◆ Feed dog height should be measured at the point where the needle is at the top position.

- For light materials ... Approx 0.8mm from throat plate
- For usual materials ... Approx 1.0mm from throat plate
- For heavy materials ... Approx 1.2mm from throat plate

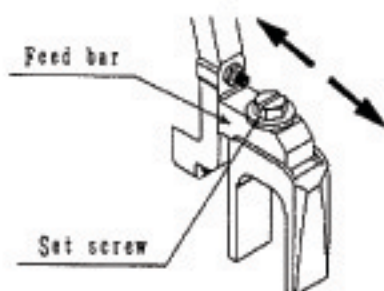
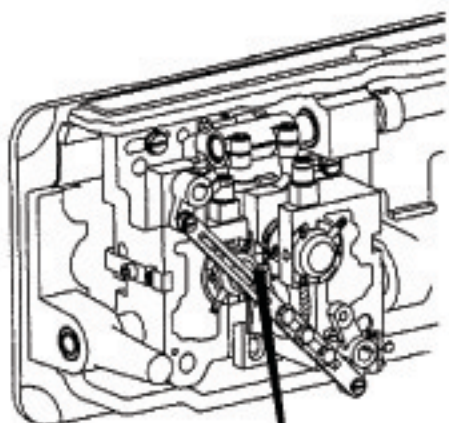

○ Adjustment procedure

- ① Lean the machine head backward
- ② Turn the handwheel by hand and stop when the feed dog rises to the maximum height.
- ③ Loosen the feed bar set screw
- ④ Vertically move the feed bar (in the direction indicated by arrow in the figure) to adjust it to adequate height.
- ⑤ After the adjustment, tighten the feed bar set screw.

The feed dog height is factory-adjusted to A mm shown table.

	Model	A (mm)
	CS-8165/-BT	1.0
	CS-8175H-BT	1.0
	CS-8175/-BT	1.2

16. RELATIONSHIP BETWEEN ROTATING HOOK MOTION AND TAKE-UP LEVER MOTION



CAUTION

TURN THE SWITCH OFF THE POWER SUPPLY TO PREVENT FROM UNEXPECTED INJURY. BE SURE TO CONFIRM THE STOP OF ROTATION OF THE MOTOR BEFORE OPERATIONS.

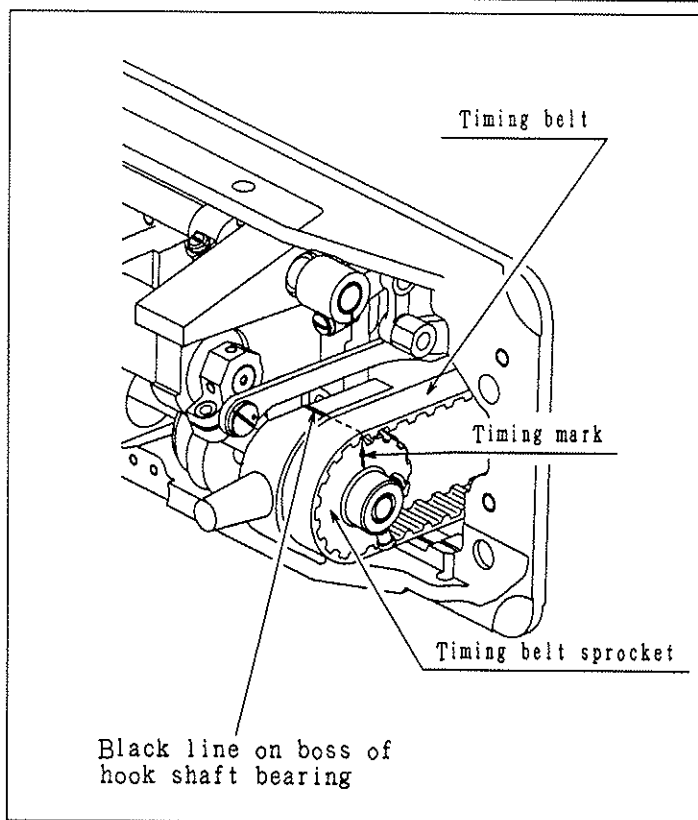

When the timing belt was removed for its replacement, for example, the relationship between rotating hook motion and take-up lever motion should be adjusted as follows :

- (1) Turn the handwheel and stop when the take-up lever is lifted to its top position
- ② Lean the machine head backward and make sure the arrow (timing mark) put on the timing belt is in line with the black line on the boss of hook shaft bearing
- ③ If the timing mark is not in line with the black line, remove the timing belt and install it again to adjust.

17. RELATIONSHIP BETWEEN HOOK MOTION AND OPENER MOTION



CAUTION

TURN THE SWITCH OFF THE POWER SUPPLY TO PREVENT FROM UNEXPECTED INJURY. BE SURE TO CONFIRM THE STOP OF ROTATION OF THE MOTOR BEFORE OPERATIONS.

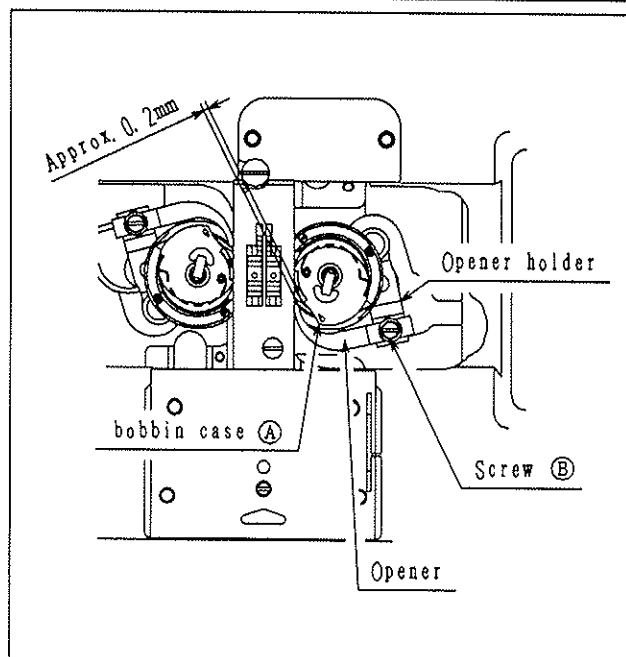

- (1) Turn the handwheel by hand and stop when the opener holder is located most remotely from the throat plate
- ② Make sure gap between the bobbin case (A) and the opener is approximately 0.2 mm.
- ③ If the gap is too large or small, loosen the opener set screw (B) and adjust position of the opener.

18. RELATIONSHIP BETWEEN NEEDLE MOTION AND FEED DOG MOTION

CAUTION

TURN THE SWITCH OFF THE POWER SUPPLY TO PREVENT FROM UNEXPECTED INJURY. BE SURE TO CONFIRM THE STOP OF ROTATION OF THE MOTOR BEFORE OPERATIONS.

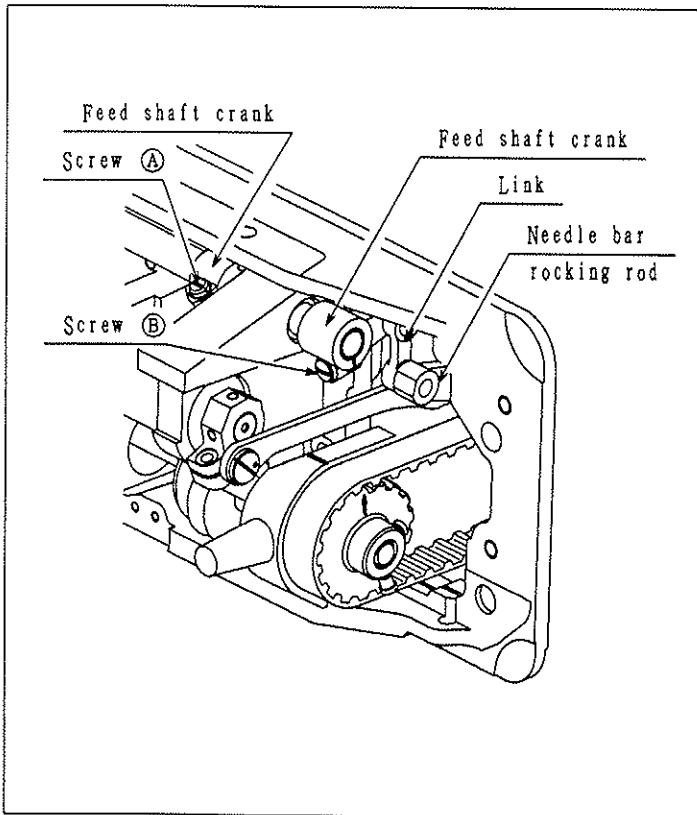

The feed dog should be adjusted so that the needle can plunge into the feed dog needle hole at the center of the hole

- ① Set stitch length to "0" on the stitch length setting dial.
- ② Lean the machine head backward
- ③ Loosen the feed shaft crank set screw A and B
- ④ Lower the needle to the lowest position
- ⑤ Adjust the distance between the pressure bar and the needle bar to be 13.5 mm and tentatively tighten the screws A and B of the feed shaft crank
- ⑥ Check that the right feed shaft crank is connected with the link at right angle, as shown in figure.
- ⑦ If the connection is not at right angle, remove the back cover, loosen the screw C and move the needle bar rocking rod in the arrow direction to adjust.
- ⑧ After the completion of adjustment, fully tighten the screws A, B and C.

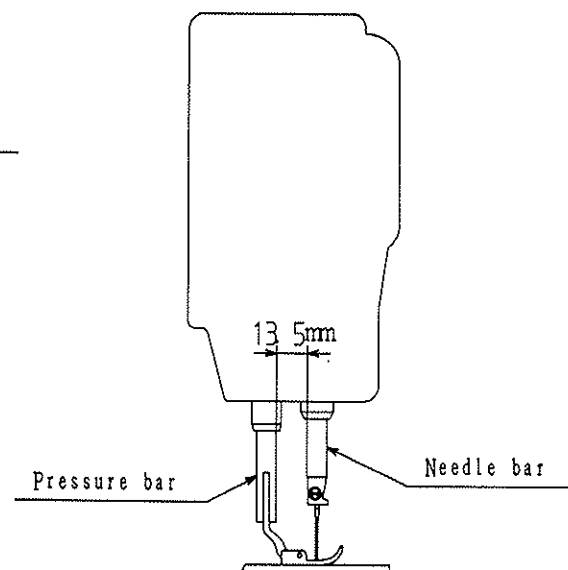
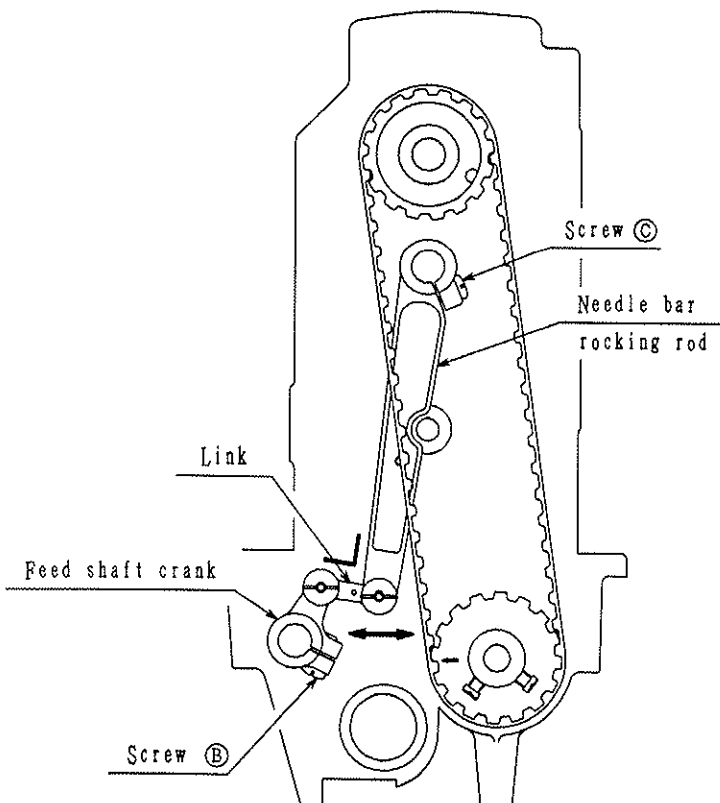

19. INSTALLATION OF MOVABLE KNIFE



CAUTION

TURN THE SWITCH OFF THE POWER SUPPLY TO PREVENT FROM UNEXPECTED INJURY. BE SURE TO CONFIRM THE STOP OF ROTATION OF THE MOTOR BEFORE OPERATIONS.

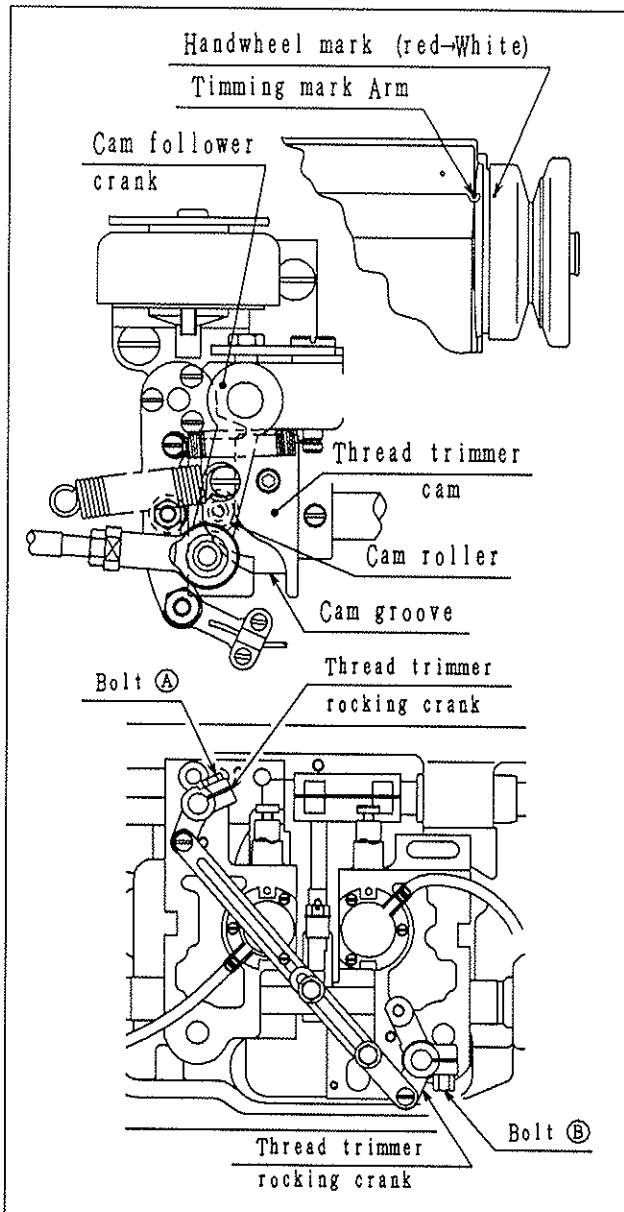

1 Initial position of movable knife

- ① Turn the handwheel and lower the needle bar to the lowest position
- ② Push the cam follower crank so that the cam roller enters into the thread trimmer cam groove when the handwheel's mark red point meets the arm's black point.
- ③ Turn the handwheel until the black mark point on the arm meets the white mark point on the handwheel. Set the cam follower crank at the position with a screwdriver temporarily preventing the cam roller coming out from the cam groove
- ④ Loosen the thread trimmer rocking crank clamp bolts ① and ②.
- ⑤ Adjust the movable knife so that the movable knife end slant portion protrudes 0~0.5 mm from the fixed knife, as shown in figure and tighten the bolts ① and ②.

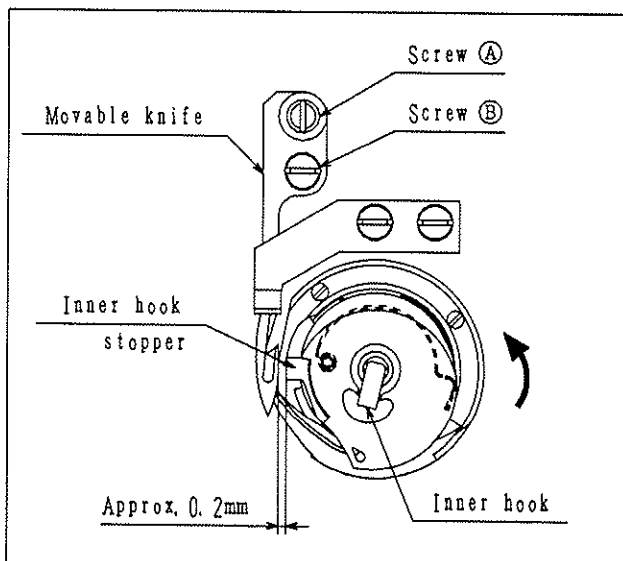
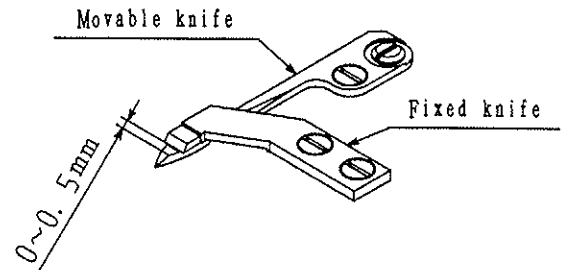

2 Gap between movable knife and inner hook stopper

- ① Turn the handwheel by hand until needle reaches the lowest position
- ② With the needle at the lowest position, depress cam follower crank, turn the handwheel until the movable knife reaches the extremity of its stroke
- ③ Manually rotate the inner hook in the direction indicated by arrow in figure and adjust gap between the movable knife and the inner hook stopper to about 0.2 mm (the screws ① and ② should be loosened for this adjustment).

20. ADJUSTMENT OF THREAD TRIMMER CAM



CAUTION

TURN THE SWITCH OFF THE POWER SUPPLY TO PREVENT FROM UNEXPECTED INJURY. BE SURE TO CONFIRM THE STOP OF ROTATION OF THE MOTOR BEFORE OPERATIONS.

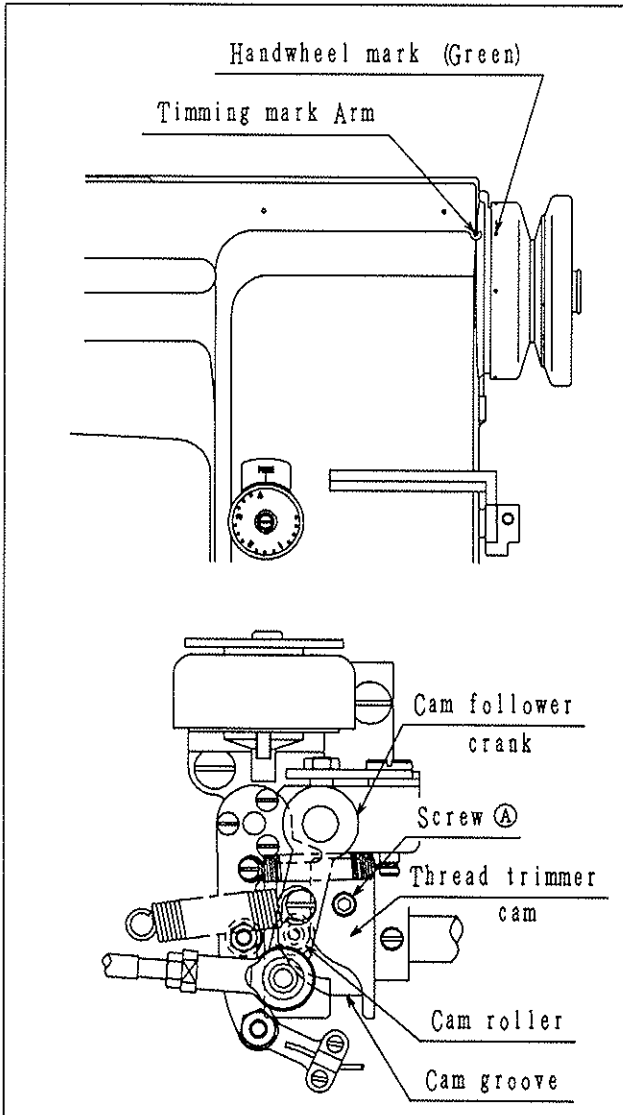

(1) Turn the handwheel by hand until the needles reach the lowest position

② Maintaining the needle position, depress the cam follower crank and put the cam roller into the groove of thread trimmer cam

③ Turning the handwheel by hand, adjust the thread trimmer cam so that the movable knife starts moving when the green mark point on the handwheel comes in line with the timing mark point on the arm
To adjust, loosen two thread trimmer cam clamp screws (A).

21. ADJUSTMENT OF THREAD TENSION REGULATOR

CAUTION TURN THE SWITCH OFF THE POWER SUPPLY TO PREVENT FROM UNEXPECTED INJURY. BE SURE TO CONFIRM THE STOP OF ROTATION OF THE MOTOR BEFORE OPERATIONS.

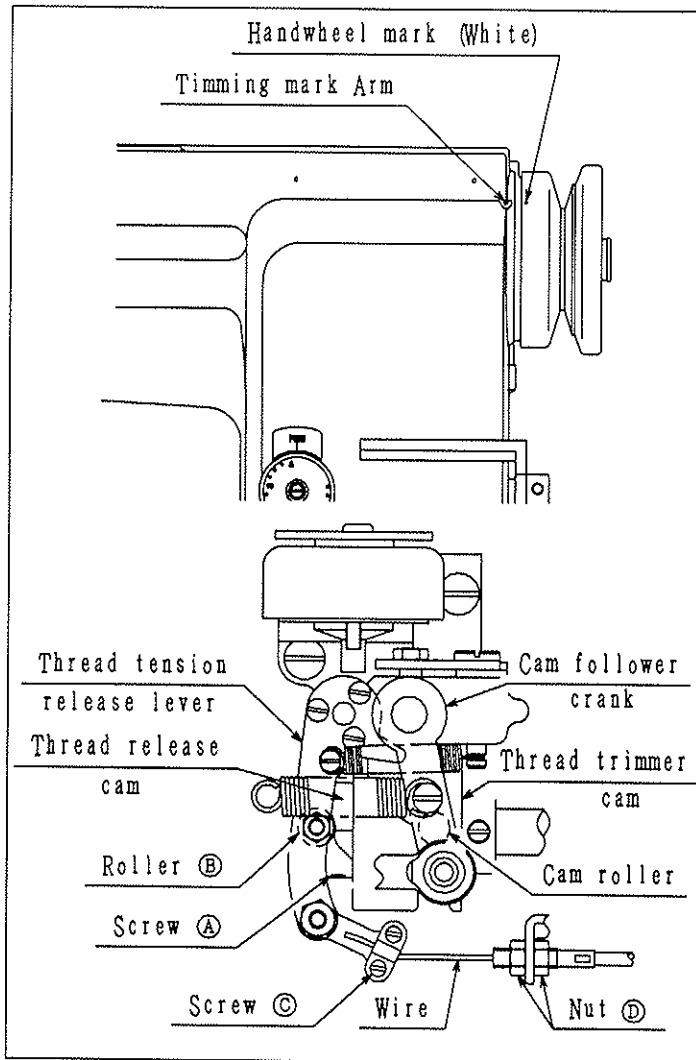

- (1) Turn the handwheel by hand until the needles reach the lowest position
- (2) Maintaining the needle position, depress the cam follower crank and put the cam roller into the groove of thread trimmer cam
- (3) Turning the handwheel by hand, adjust the thread tension release cam so that the tension disc close when the white mark point on the handwheel comes in line with the timing mark point on the arm
To adjust, loosen two tension release cam clamp screws (A).
- (4) Opening degree of tension disk should be adjusted with the tension release roller (B) mounted on the convex portion of thread release cam, as shown in Fig
To adjust, loosen the screws (C) and draw the wire
- (5) Make fine adjustment by loosening the nut (D).

22. ADJUSTMENT OF MESHING PRESSURE OF MOVABLE KNIFE AND FIXED KNIFE

CAUTION TURN THE SWITCH OFF THE POWER SUPPLY TO PREVENT FROM UNEXPECTED INJURY. BE SURE TO CONFIRM THE STOP OF ROTATION OF THE MOTOR BEFORE OPERATIONS.

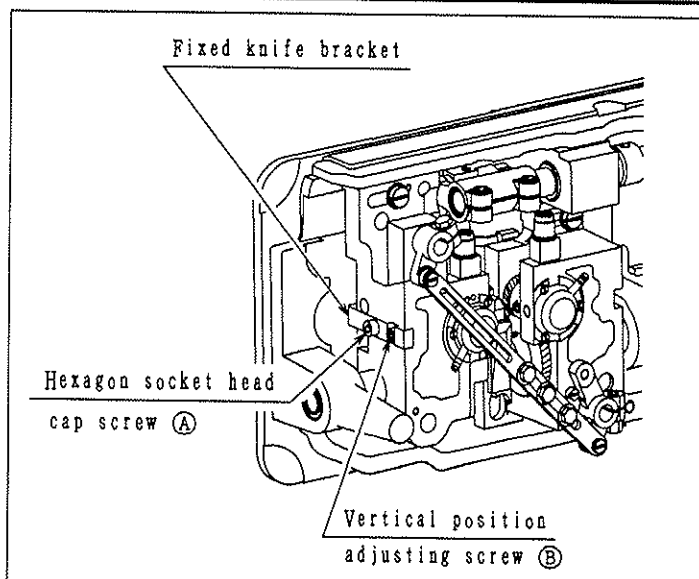

- (1) Loosen the fixed knife bracket clamp hexagon socket head cap screw (A).
- (2) Turn the vertical position adjusting screw (B) to adjust meshing pressure and then tighten the hexagon socket head cap screw (A).

Note: Since excess pressure causes large torque to the thread trimming mechanism and trimming failure, adjust it so that thread can be trimmed with minimum pressure.

- (3) Move the movable knife and check that the thread can be sharply trimmed.

23. ADJUSTMENT FOR CHANGE OF NEEDLE GAUGE



TURN THE SWITCH OFF THE POWER SUPPLY TO PREVENT FROM UNEXPECTED INJURY. BE SURE TO CONFIRM THE STOP OF ROTATION OF THE MOTOR BEFORE OPERATIONS.

- (1) Replace the throat plate, feed dog and needle clamp
 Since the throat plate and feed dog are special parts designed for thread trimming machine, be sure to use those specified by us.)
- ⑦ Lean the machine head backward
- ⑧ Loosen two connecting link clamp bolts ①.
- ④ Remove the spring ③.
- ⑤ Loosen the hook bracket clamp screws ② and ⑥ and adjust gap between each needle and hook
- ⑥ When the needles and hooks have been adjusted, install the spring ③.
- ⑦ Contact the rocking cranks ③ and ④ to the stopper pins ⑤ and ⑥ and tighten the connecting link clamp bolt ①.
- ⑧ Turn the handwheel by hand until the needles reach the lowest position
- ⑨ Loosen the nut ⑦ and ⑧.
- (10) Depress the cam follower crank ⑩ and adjust the connecting rod ⑪ so that the cam roller can smoothly enter the groove of thread trimmer cam Then tighten the nuts ⑦ and ⑧.
- (11) Adjustment of the cam groove and the cam roller
 - (a) Push the cam follower crank ⑩ so that the cam roller enters into the cam groove
 - (b) Turn the connecting rod ⑪ and adjust the clearance between the cam roller and the cam groove surface ⑫ as small as possible, and tighten the nuts ⑦ and ⑧.
 - (c) Push the cam follower crank ⑩ again and check that the cam roller enters into the thread trimmer cam groove smoothly.

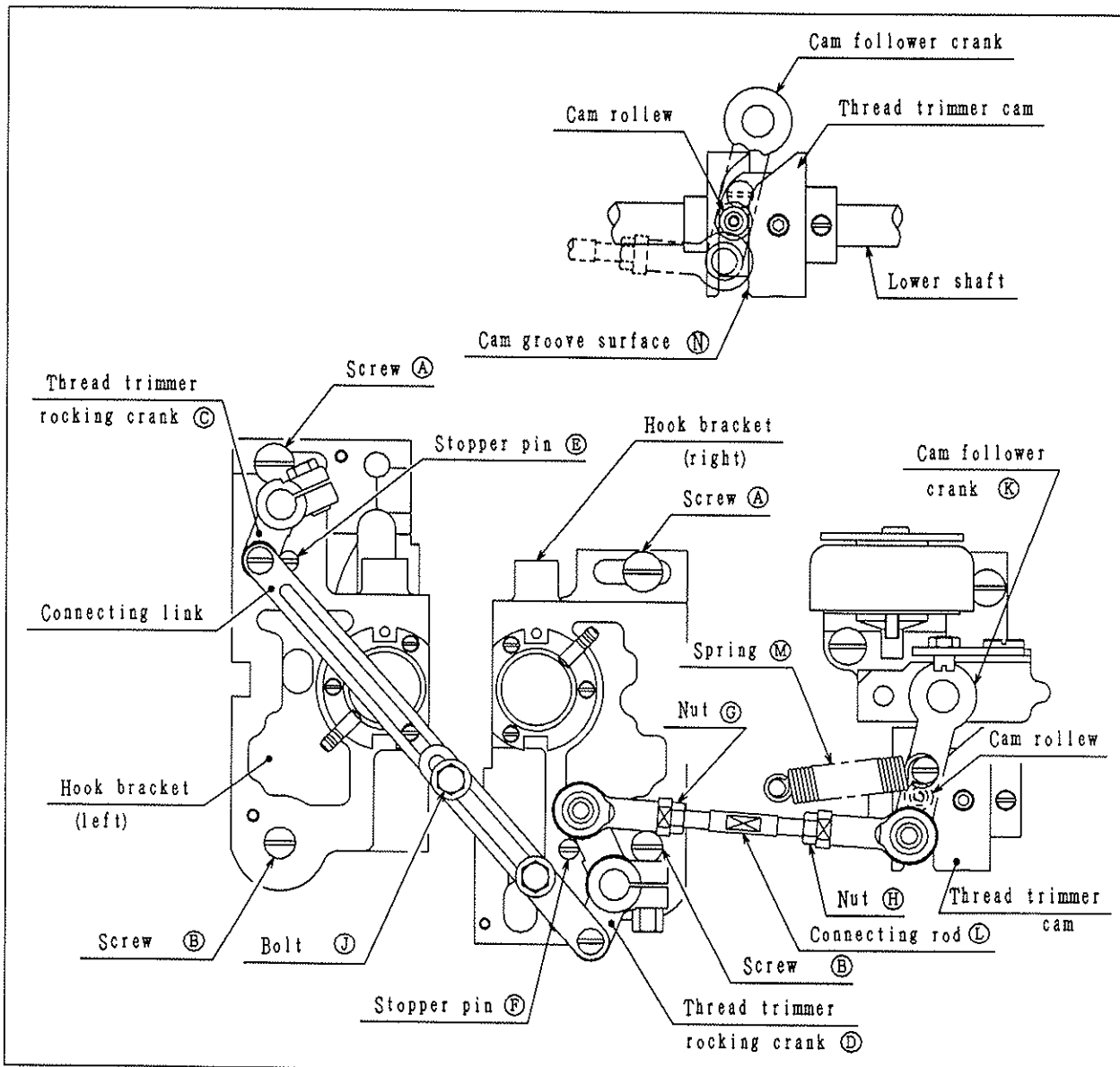

⚠ CAUTION TURN THE SWITCH OFF THE POWER SUPPLY TO PREVENT FROM UNEXPECTED INJURY. BE SURE TO CONFIRM THE STOP OF ROTATION OF THE MOTOR BEFORE OPERATIONS.

- ① Run the machine then stop at "UP" position
- ② Loosen the screw ③, then adjust the base block so that the line ④ and the line ⑤ are the same plane, then tighten the screw ③.
- ③ Loosen the screw ⑥, then adjust the wiper move so as the ⑦ clearance is 2 mm, then tighten the screw ⑥.

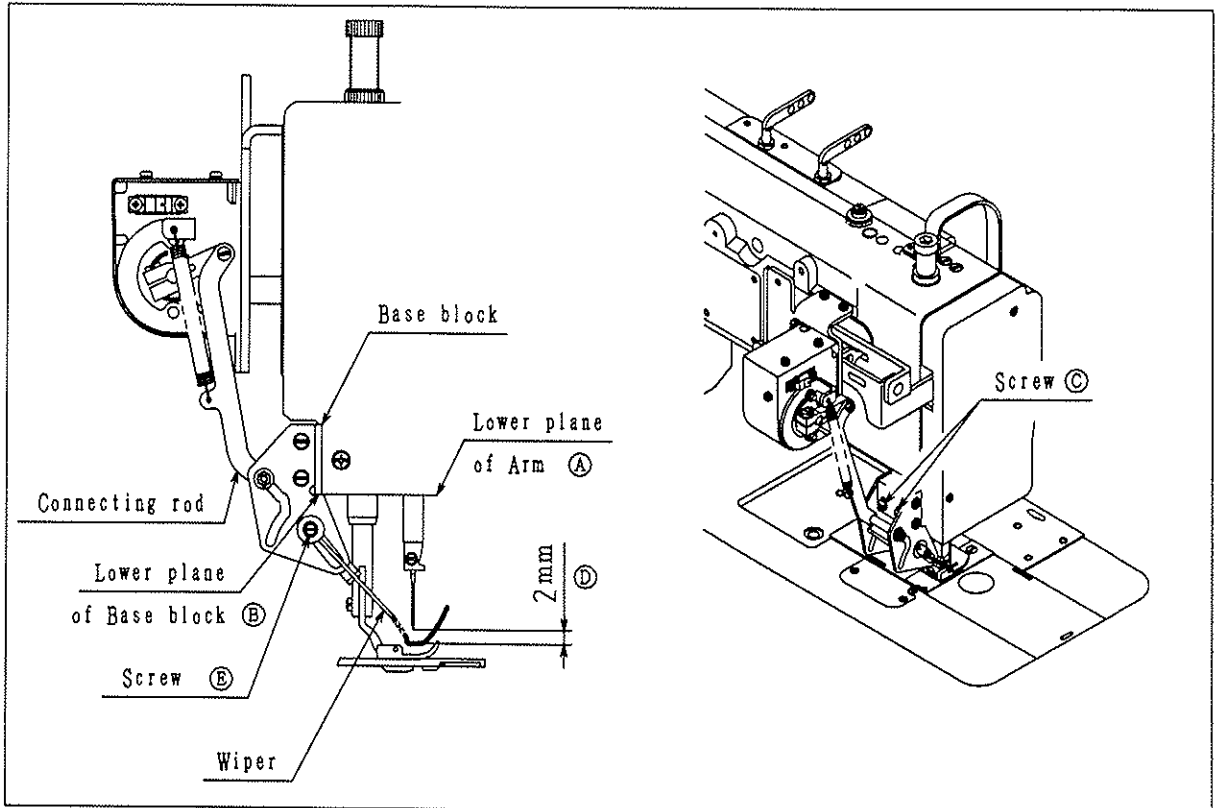

24. STOP OF THE NEEDLE BARS

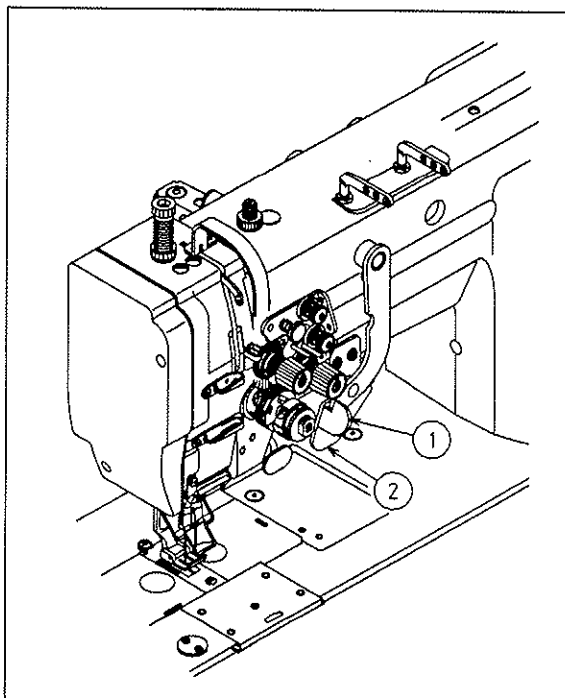

- To stop operation of the left needle bar
Move the stop lever ① to the "L" position
- To stop operation of the right needle bar
Move the stop lever ① to the "R" position
- To resume the two needle mode
Press the push lever ② the stop lever ① then return to its original position

Attention:

Do not change over the sewing mode to the singlestitch sewing mode when the sewing runs at high speed

25 STITCH-TO-ANGLE TABLE BY GAUGE (Pitch and mm conversion table)

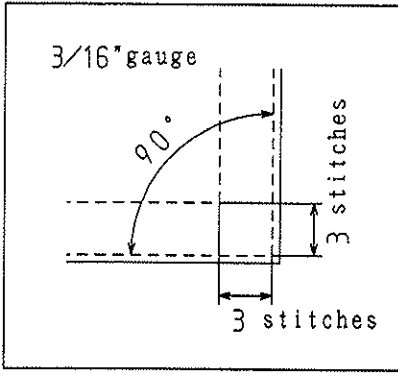

[Example]

For a sewing angle of 90° and a sewing pitch of 1.6 mm the number of stitches becomes 3.

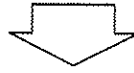

Observe the "90°" columns on the table of the number of stitches by stitch length gauges to search for the column in which "1.6" is indicated. Then, you can find "3" on the top of the "1.6" lines. This means the number of stitches is 3.

Gauge	Sewing angle	Number of stitches									Gauge	Sewing angle	Number of stitches								
		1	2	3	4	5	6	7	8	9			1	2	3	4	5	6	7	8	9
1/8" (17mm)	40°		4.4	2.9	2.2	1.7	1.5				9/32" (7.14mm)	40°			4.9	3.9	3.3	2.8	2.5	2.2	
	50°		3.4	2.3	1.7					50°				5.1	3.8	3.1	2.6	2.2	1.9	1.7	
	60°		2.7	1.8						60°				4.1	3.1	2.5	2.1	1.8	1.5		
	70°	4.5	2.3	1.5						70°		5.1	3.4	2.5	2.0	1.7	1.5				
	80°	3.8	1.9							80°		4.3	2.8	2.1	1.7	1.4					
	90°	3.2	1.6							90°		3.6	2.4	1.8	1.4						
	100°	2.6								100°		3.0	2.0	1.5							
5/32" (9.5mm)	40°			3.6	2.7	2.2	1.8	1.6		5/16" (7.93mm)	40°				4.4	3.7	3.2	2.8	2.5		
	50°		4.2	2.8	2.1	1.7			50°				4.3	3.4	2.9	2.5	2.2	1.9			
	60°		3.4	2.3	1.7				60°				4.6	3.5	2.8	2.3	2.0	1.8	1.6		
	70°		2.8	1.9					70°				3.8	2.9	2.3	1.9	1.7	1.5			
	80°	4.7	2.4	1.6					80°		4.8	3.2	2.4	1.9	1.6						
	90°	4.0	2.0						90°		4.0	2.7	2.0	1.6							
	100°	3.3	1.7						100°		3.4	2.3	1.7								
3/16" (4.76mm)	40°				3.3	2.6	2.2	1.9	1.6	1.5	3/8" (9.52mm)	40°					4.4	3.7	3.3	2.9	
	50°			3.4	2.6	2.0	1.7	1.5		50°					4.1	3.4	2.9	2.6	2.3		
	60°			2.7	2.1	1.6	1.4			60°					4.1	3.3	2.7	2.4	2.1	1.8	
	70°		3.4	2.3	1.7	1.4				70°					4.5	3.4	2.7	2.3	1.9	1.7	
	80°		2.8	1.9	1.4					80°					3.8	2.8	2.3	1.9	1.6		
	90°	4.8	2.4	1.6						90°		4.8	3.2	2.4	1.9	1.6					
	100°	4.0	2.0							100°		4.0	2.7	2.0	1.6						
7/32" (5.56mm)	40°				5.1	3.8	3.1	2.5	2.2	1.9	1.7	1/2" (12.7mm)	40°					5.8	5.0	4.4	3.9
	50°			4.0	3.0	2.4	1.7	1.5		50°					5.5	4.5	3.9	3.4	3.0		
	60°		4.8	3.2	2.4	1.9	1.6			60°					5.5	4.4	3.7	3.1	2.8	2.4	
	70°		4.6	2.6	2.0	1.6				70°					4.5	3.6	3.0	2.6	2.3	2.0	
	80°		3.3	2.2	1.7					80°					5.1	3.8	3.1	2.5	2.2	1.9	1.7
	90°	5.6	2.8	1.9	1.4					90°					4.2	3.2	2.5	2.1	1.8	1.6	1.4
	100°	4.7	2.3	1.6						100°	5.3		3.6	2.7	2.1	1.8	1.5	1.3			
1/4" (6.35mm)	40°				4.4	3.5	2.9	2.5	2.2	2.0											
	50°			4.6	3.4	2.8	2.3	2.0	1.7	1.6											
	60°			3.7	2.8	2.2	1.9	1.6													
	70°		4.6	3.1	2.3	1.9	1.6														
	80°		3.8	2.6	1.9	1.6															
	90°		3.2	2.2	1.6																
100°		2.7	1.8																		

26. TROUBLE AND CORRECTIVE MEASURES

Trouble	Causes	Corrective measures
1. Thread breakage (Thread frays or wears out.) (Needle thread remains 2 to 3 cm on the wrong side of the cloth.)	<ul style="list-style-type: none"> ① The thread path, needle point, hook point or bobbin case positioning finger has scratches. ② The needle thread tension is too high. ③ The needle hits the hook point. ④ Lubrication to hook is inadequate. ⑤ The needle thread tension is too low. ⑥ The thread take-up spring has an excessively high tension while it has an excessively small stroke. ⑦ The timing between the needle and hook is too early or late. 	<ul style="list-style-type: none"> ○ Remove the scratches on the hook point using a fine sand paper. Buff the bobbin case positioning finger. ○ Properly adjust the needle thread tension. ○ See '14 NEEDLE TO HOOK RELATIONSHIP'. ○ Properly adjust the lubrication. See '5 REFUELING ADJUSTMENT OF THE HOOK'. ○ Properly adjust the needle thread tension. ○ Decrease the tension, and increase the stroke. ○ See '14 NEEDLE TO HOOK RELATIONSHIP'.
2. Stitch skipping	<ul style="list-style-type: none"> ① The clearance between the needle hook point and the is too large. ② The timing between the needle and hook is too early or late. ③ The presser foot pressure is too low. ④ The clearance between the top edge of the needle eyelet and the hook point is not correct. ⑤ The size of the needle is wrong. ⑥ A synthetic fiber thread or thin thread is used. 	<ul style="list-style-type: none"> ○ See '14 NEEDLE TO HOOK RELATIONSHIP'. ○ See '14 NEEDLE TO HOOK RELATIONSHIP'. ○ Increase the presser foot pressure. ○ See '14 NEEDLE TO HOOK RELATIONSHIP'. ○ Replace the needle by one which one grade thicker. ○ Wind the thread round the needle as illustrated. 
3. Loose stitches	<ul style="list-style-type: none"> ① The thread has not been passed through the notch of the bobbin case tension spring. ② The thread path is poorly finished. ③ The bobbin does not rotate smoothly. ④ The bobbin thread tension is too low. ⑤ The bobbin thread has been wound too tight. 	<ul style="list-style-type: none"> ○ Properly thread the bobbin case. ○ Grind it using a fine sand paper or a buff. ○ Replace the bobbin or hook. ○ Properly adjust the tension. ○ Decrease the bobbin thread winding tension.
4. The thread slips off the needle up on being trimmed	<ul style="list-style-type: none"> ① The tension of the auxiliary thread tension controller is too high. ② The thread trimming timing is too early. ③ The returning force of the thread take-up spring is too high. 	<ul style="list-style-type: none"> ○ Decrease the tension. ○ See '21. ADJUSTMENT OF THREAD TENSION REGULATOR'. ○ See '20. ADJUSTMENT OF THREAD TRIMMER CAM'. ○ Adjust the height of the thread take-up spring.
5. The needle thread cannot be trimmed, while the bobbin thread can be trimmed	<ul style="list-style-type: none"> ① The last stitch has been skipped. (The clearance between the needle and the hook is too large.) 	<ul style="list-style-type: none"> ○ See '14 NEEDLE TO HOOK RELATIONSHIP'.
6. Both needle and bobbin threads cannot be trimmed	<ul style="list-style-type: none"> ① The thread trimming timing is wrong. ② The knife has been damaged. ③ The knife pressure is inadequate. ④ The home position of the movable knife is inaccurate. ⑤ The movable knife fails to work. ⑥ The thread trimming solenoid fails to work. 	<ul style="list-style-type: none"> ○ See '20. ADJUSTMENT OF THREAD TRIMMER CAM'. ○ Replace the knife. ○ Increase the knife pressure. ○ See '20. ADJUSTMENT OF THREAD TRIMMER CAM'. ○ Check it by actuating it by hand. ○ Check the motor solenoid for proper operation.
7. Thread cannot be trimmed sharply	<ul style="list-style-type: none"> ① The thread trimming timing is wrong. ② The knife pressure is inadequate. ③ The knife blade is blunt. 	<ul style="list-style-type: none"> ○ See '20. ADJUSTMENT OF THREAD TRIMMER CAM'. ○ Increase the knife pressure. ○ Replace the knife.

GOLDEN WHEEL CHEE SIANG INDUSTRIAL CO., LTD
啓翔股份有限公司
No. 32, Wu Chuan 7th Road, Wu Ku Industrial Area,
Wu Ku Hsiang 24248, Taipei Hsien, Taiwan
Tel: 886-2-22999518 Fax: 886-2-22999519

* Appear and specification listed in this instruction manual are subjected to change without notice.

02.07 printed in Taiwan